

## ECE 523: Homework #4

**Due Session 24 (Oct. 19 on campus, Nov. 2 for Engineering Outreach)**

1. Given the system below do the following:
  - (a) Sketch the sequence equivalent circuits series faults occurring on line 1 (Bus 1) and reduce them to simplified equivalents
  - (b) Determine the phase currents from Bus 1 to Bus 2 on each line if phase A is open on line 1 (treat it as the breaker at Bus 1 on phase A is open and phases B and C are closed)
  - (c) Determine the phase currents from Bus 1 to Bus 2 on each line if phases B and C are open (treat this as the breaker having phase A closed and phases B and C open)
  - (d) Suppose that line 1 is series compensated, with each phase having a capacitive impedance of  $-j0.3\text{pu}$ . The capacitor on phase A is bypassed by a circuit breaker and phases B and C are inserted. Calculate the currents from Bus 1 to Bus 2 on each line.

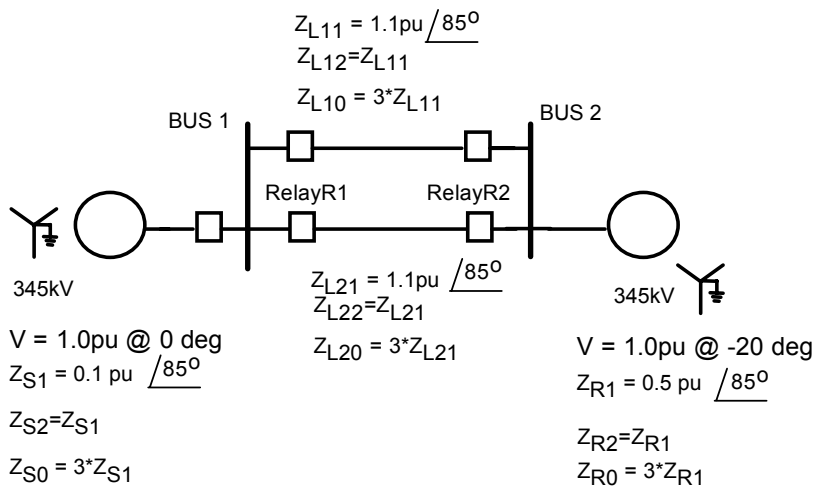

2. Do the following for the circuit below using Zbus matrix methods:
- Calculate positive, negative and zero sequence equivalent circuits based on a fault 50% of the way down line 2 (the lower of the two lines).
  - Calculate the voltages and currents at RelayR1 and RelayR2, for 3 phase, SLG, LL, and DLG faults with  $R_f = 0$ .
  - Repeat the part (b) for a SLG fault with  $R_f = 0.75$  pu.

